

Anpresskraft:
Max. 12 ton
Min. 1 ton

Auch Verfügbar in
Ø180-7"

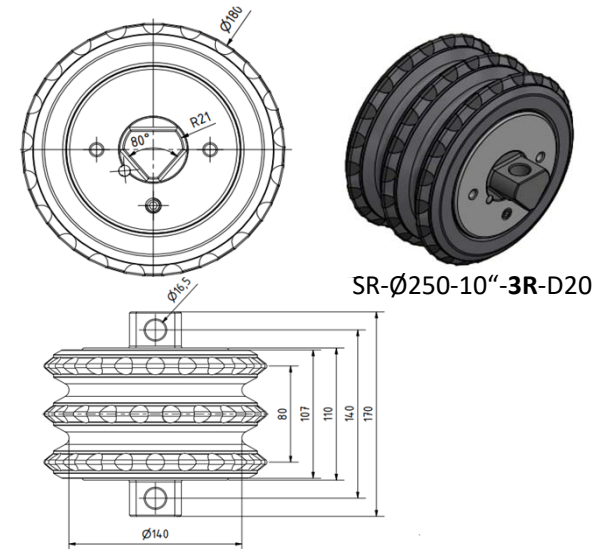
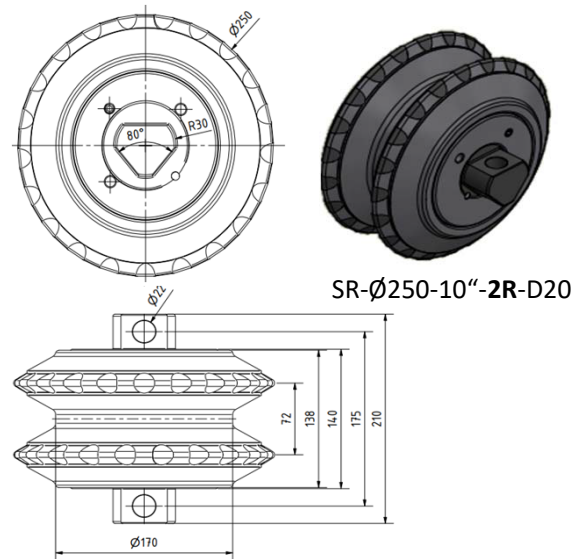
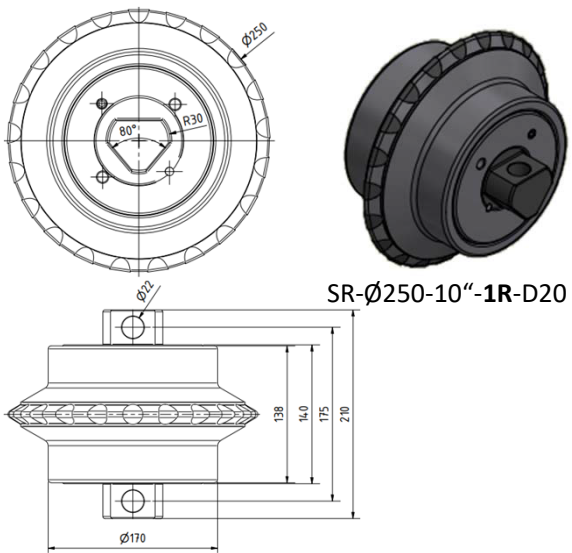
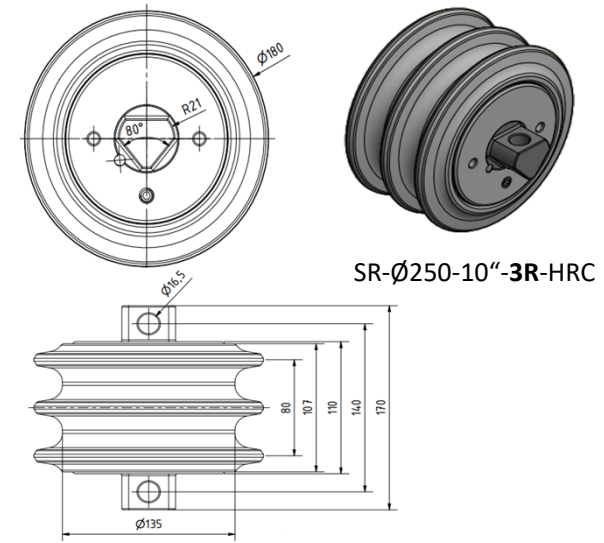
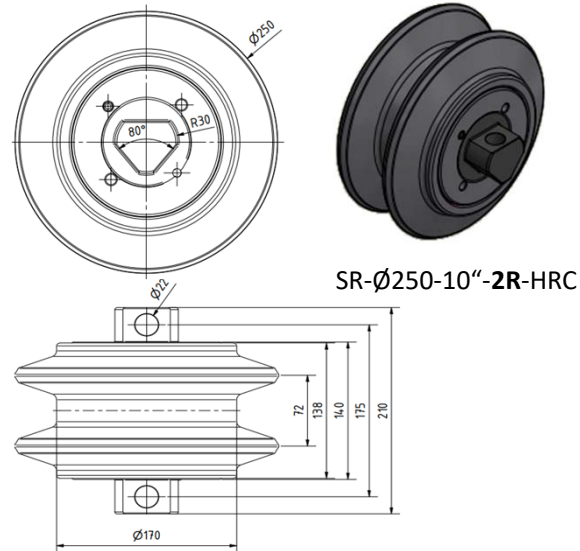
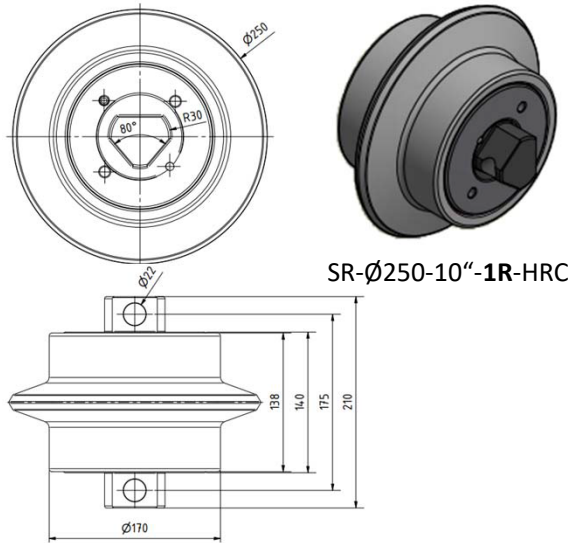

Anpresskraft:
Max. 16 ton
Min. 1.4 ton

Auch Verfügbar in
Ø280-11"

